

Datasheet

Features

- Cmos Colour Sensor :
 - 8192 RGB Pixels, 5 x 5µm (Full Definition)
 - 4096 RGB Pixels 10x10µm (True Colour)
- Interface : CameraLink® (up to 10 Taps at 85MHz)
- Line Rate :
 - Up to 50000 l/s In 8k Full Definition Mode
 - Up to 66000 l/s in 4k True Colour Mode
- Bit Depth : 24bits (RGB 8bits)
- Scan Direction
- Flat Field Correction
- Low Power Consumption : <9W
- F-Mount compliance



Description

e2v's next generation of line scan cameras are setting new, high standards for line rate and image quality. Thanks to e2v's recently developed multi-line CMOS technology, the camera provides an unmatched 100,000 lines/s and combines high response with an extremely low noise level; this delivers high signal to noise ratio even when short integration times are required or when illumination is limited. The 5µm pixel size is arranged in four active lines and dual line filter configuration allowing the camera to be operated in several modes: True colour mode with 10µm RGB pixels to provide equivalent colour fidelity to 10µm pixel tri-linear solutions with advanced immunity to web variation or Full definition mode with a 8192 RGB pixel resolution.

Application

- Raw material surface inspection
- Flat panel display inspection
- PCB inspection
- Solar cell inspection
- Parcel and postal sorting
- High resolution document scanning
- Print and paper inspection



Key Specifications

Characteristics	Typical Value		Unit
Sensor Characteristics at Maximum Pixel Rate			
Resolution	8192	4096	RGB Pixels
pixel size (square)	5	10	µm
Max Line Rate	50	66	kHz
Radiometric Performance at Maximum Pixel Rate and minimum camera gain			
Bit depth	3 x 8		Bits
Response non linearity	< 1		%
PRNU HF Max	3		%
Dynamic range	65		dB
Peak Response (All Modes)			
Red	11.8		LSB 8bits/(nJ/cm ²)
Green	11.2		LSB 8bits/(nJ/cm ²)
Blue	7.8		LSB 8bits/(nJ/cm ²)

Test conditions :

- All values are given at Nominal Gain (0dB) : Preamp Gain x1, Amp Gain 0dB
- Figures in LSB are for a 8bits format
- Measured at exposure time = 400µs and line period = 400µs in Ext Trig Mode (Max Exposure Time)
- Maximum data rate

Functionality (Programmable via GenICam Control Interface)		
Analog Gain	Up to 12 (x4)	dB
Offset	-4096 to +4096	LSB
Trigger Mode	Timed (Free run) and triggered (Ext Trig, Ext ITC) modes	
Sensor Modes	<ul style="list-style-type: none"> • True Color Enhanced : 4096 RGB Pixels of 10x10µm • True Color Single : 4096 RGB Pixels of 10x10µm • Full Definition Enhanced : 8192 RGB Pixels 5x5µm • Full Definition Single : 8192 RGB Pixels 5x5µm 	
Mechanical and Electrical Interface		
Size (w x h x l)	126 x 60 x 35	mm
Weight	360	g
Lens Mounts	F, T2, M42	-
Sensor alignment	±100	µm
Sensor flatness	±35	µm
Power supply	12 - 24	V
Power dissipation	< 9	W
General Features		
Operating temperature	0 to 55 (front face) or 70 (Internal)	°C
Storage temperature	-40 to 70	°C
Regulatory	CE, FCC and RoHS compliant	

Image Sensor and color modes

The Eliixa+ Colour 8k sensor is composed of two pairs of sensitive lines.

The Colour version has been completed with RGB colour Filter and disposed as detailed beside.

Each pair of lines uses the same Analog to Digital Column converter (ADC Column). An appropriate (embedded) Time delay in the exposure between each line this allows to combine two successive exposures in order to double the sensitivity of a single line.

This Time Delay Exposure is used only in the Full Definition Enhanced mode (See Below).

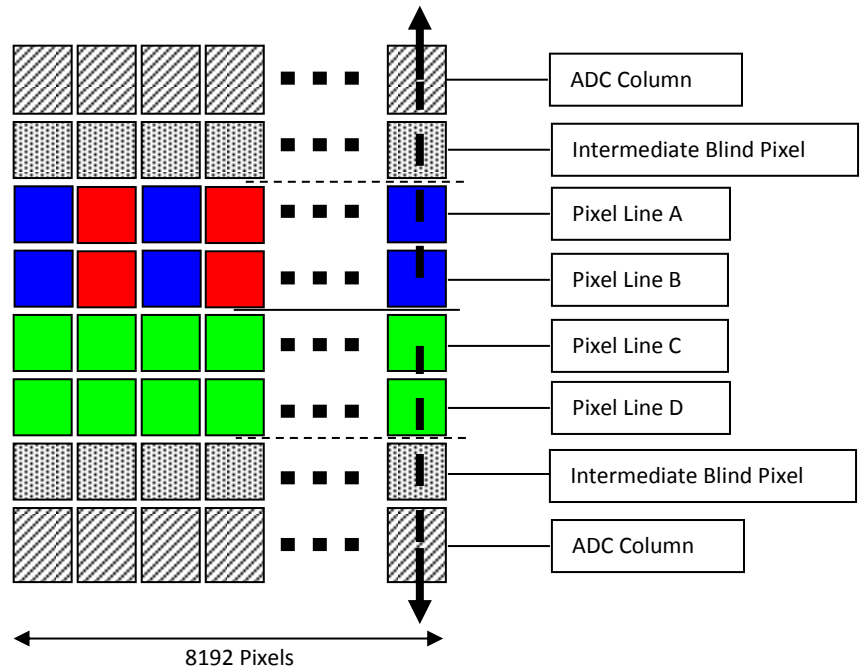

Full Definition Single Mode (FDS)

5 μ m Pixels (R,G,B)

Same definition than B&W

Requires x3 the data flow of the B&W

- Sensitivity is half of the TC mode available : Equivalent to 3 x Pixels of 5 μ m (with their respective colour filters).
- “Full Exposure control” not needed in this mode as the Time Delay Exposure is not active. The Exposure time can be control as for a single line mode.

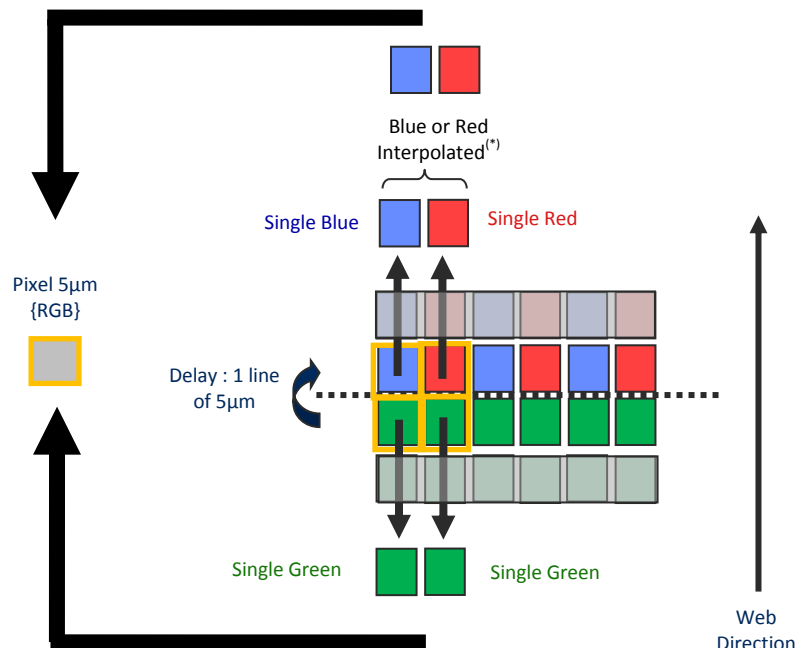

Full Definition Enhanced Mode (FDE)

5µm Pixels (R,G,B)

Same definition than B&W

Requires x3 the data flow of the B&W

- Sensitivity is the same as the TC mode available : Equivalent to 6 x Pixels of 5µm (with their respective colour filters).
- “Full Exposure control” is activated in this mode as the Time Delay Exposure is active.

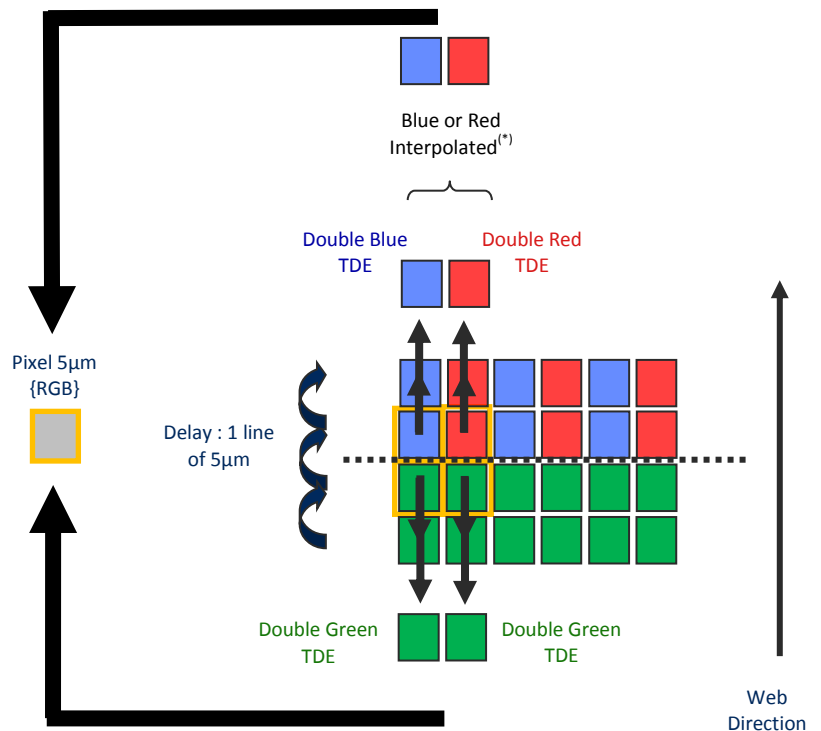

Color Interpolation in Full Definition modes.

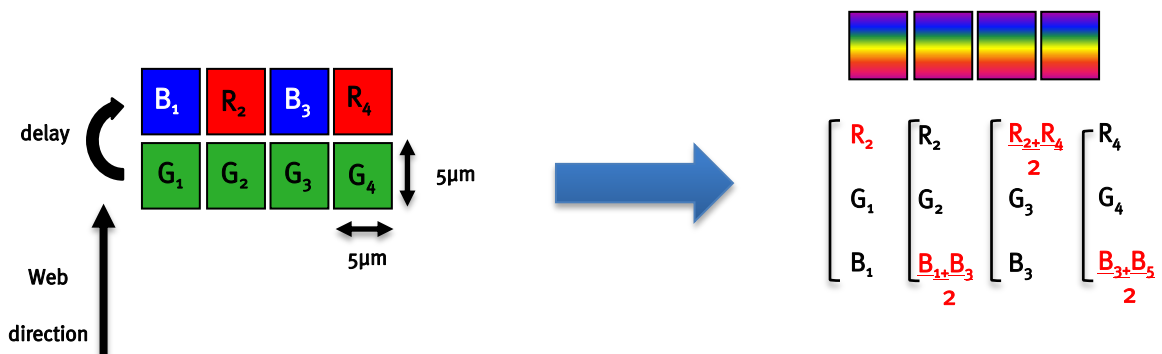

This color mode (5µm) requires the indication of “Forward/Reverse” to the camera in order to manage the delay between the two coloured lines.

True Colour Enhanced Mode (TCE)

10µm Pixels (R,G,B)
 Twice less pixels than B/W
 Requires $\times 3/2$ the data flow of B&W

- High Sensitivity True Color mode: Equivalent to 6 x Pixels of 5µm (with their respective colour filters).
- “Full Exposure control” not needed in TC as the TDI is not active (only binning). The Exposure time can be control as for a single line mode.

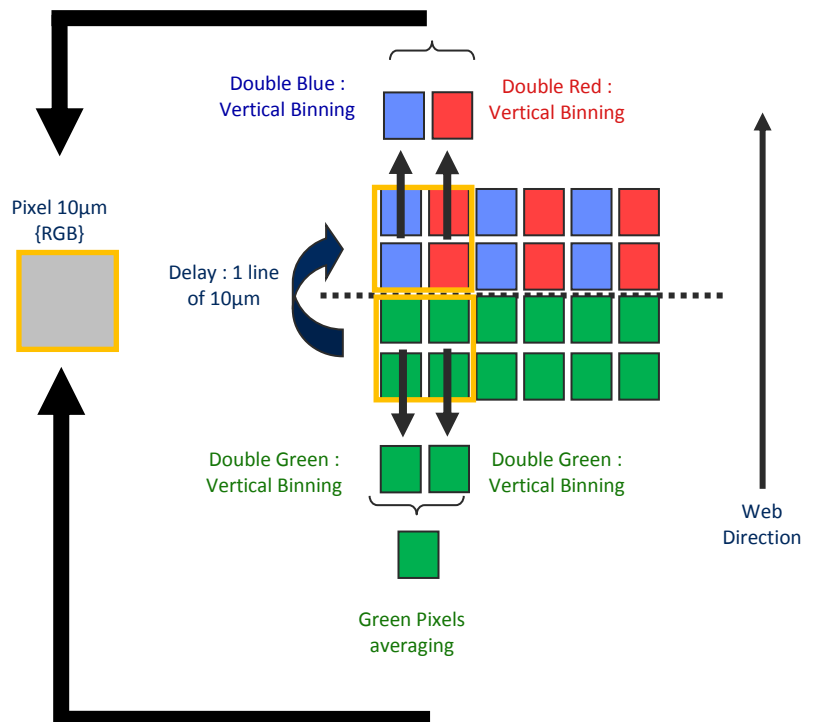

True Colour Single Mode (TCS)

10µm Pixels (R,G,B)
 Twice less pixels than B/W
 Requires $\times 3/2$ the data flow of B&W

- Sensitivity Half of the TCE mode: Equivalent to 6 x Pixels of 5µm (with their respective colour filters).
- “Full Exposure control” not needed in TC as the TDI is not active (only binning). The Exposure time can be control as for a single line mode.
- Not sensitive to the Scanning direction and the variation of the aspect ratio of the image.

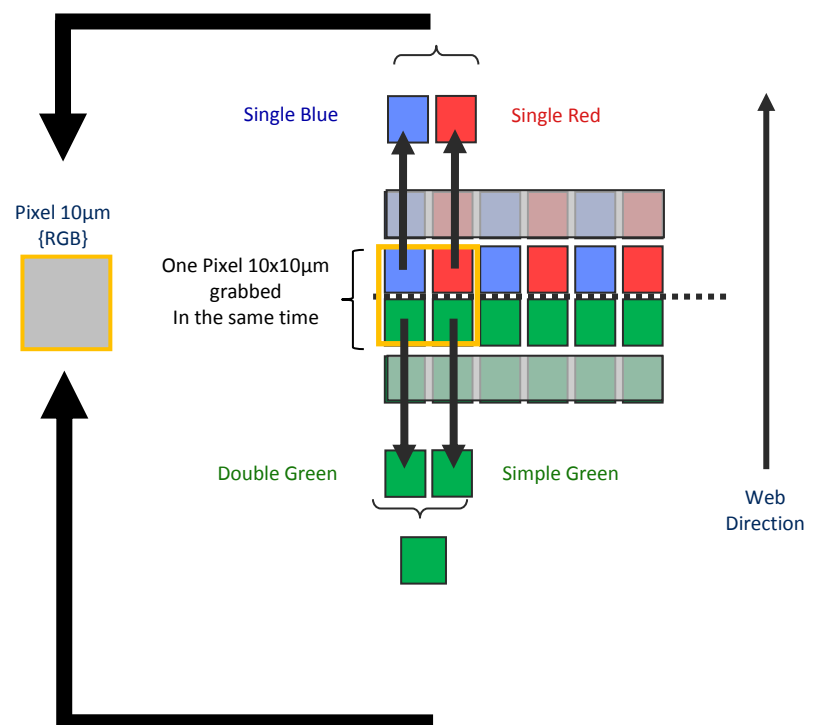

Column Interpolation Correction

This interpolation is used to compensate the color error in the Red or the Blue in case of a vertical transition on the web : The Red or the Blue value of each colored pixel is corrected if the variation between two neighbour green pixels is significant.

$B_1' = \alpha_B \times B_1$ and α_B is the blue correction, calculated with the variation $(G_1 - G_2)$

$R_2' = \alpha_R \times R_2$ and α_R is the red correction, calculated with the variation $(G_1 - G_2)$

- This interpolation is available for all pixel sizes : 5x5µm but also 10x10µm
- It can be disabled by the customer. By default, it is enabled.

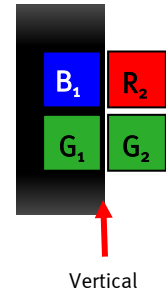

Line Interpolation Correction

This interpolation is used to compensate the color error in the Red or the Blue in case of a horizontal transition on the web in the same "True Color" pixel : A line is memorized and the Red or the Blue value of each colored pixel is corrected if the variation between two consecutive green values (previous to next line) is significant :

$B_1' = \alpha_B \times B_1$ and α_B is the blue correction, calculated with the variation $(G_1 - G'_1)$

$R_2' = \alpha_R \times R_2$ and α_R is the red correction, calculated with the variation $(G_2 - G'_2)$

- This interpolation is available only for pixel size 10x10µm (True Color Single only)
- It can be enabled by the customer. By default, it is disabled
- This interpolation requires the Forward/Reverse indication sent to the camera for the memorized line.

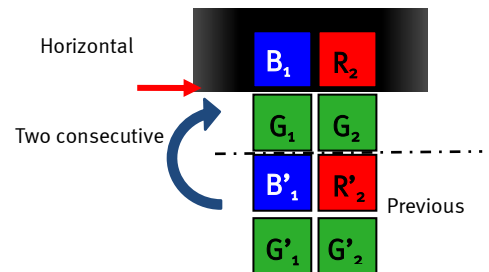

Effects of the interpolations

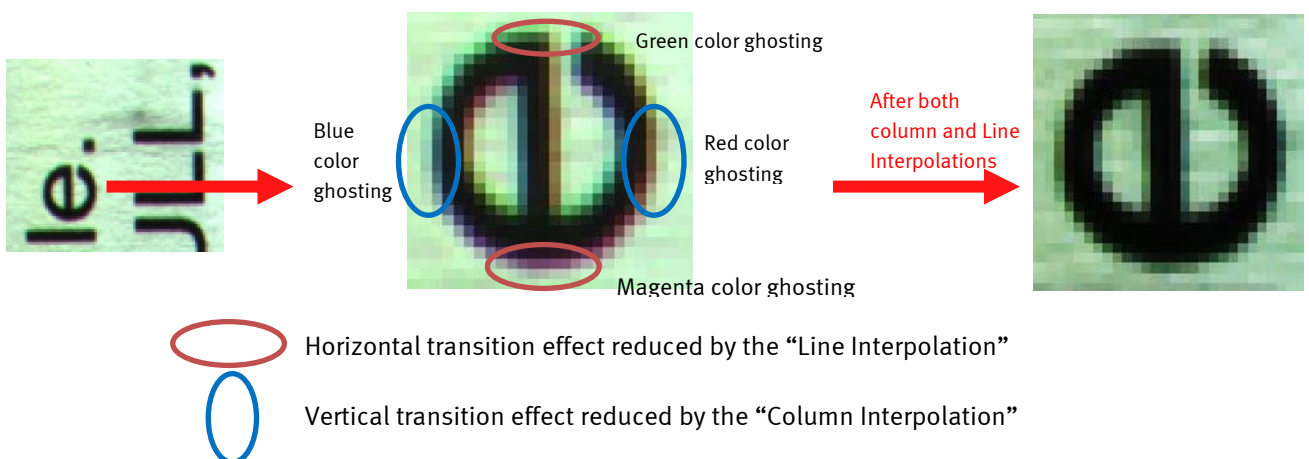

Response & QE curves

Quantum Efficiency

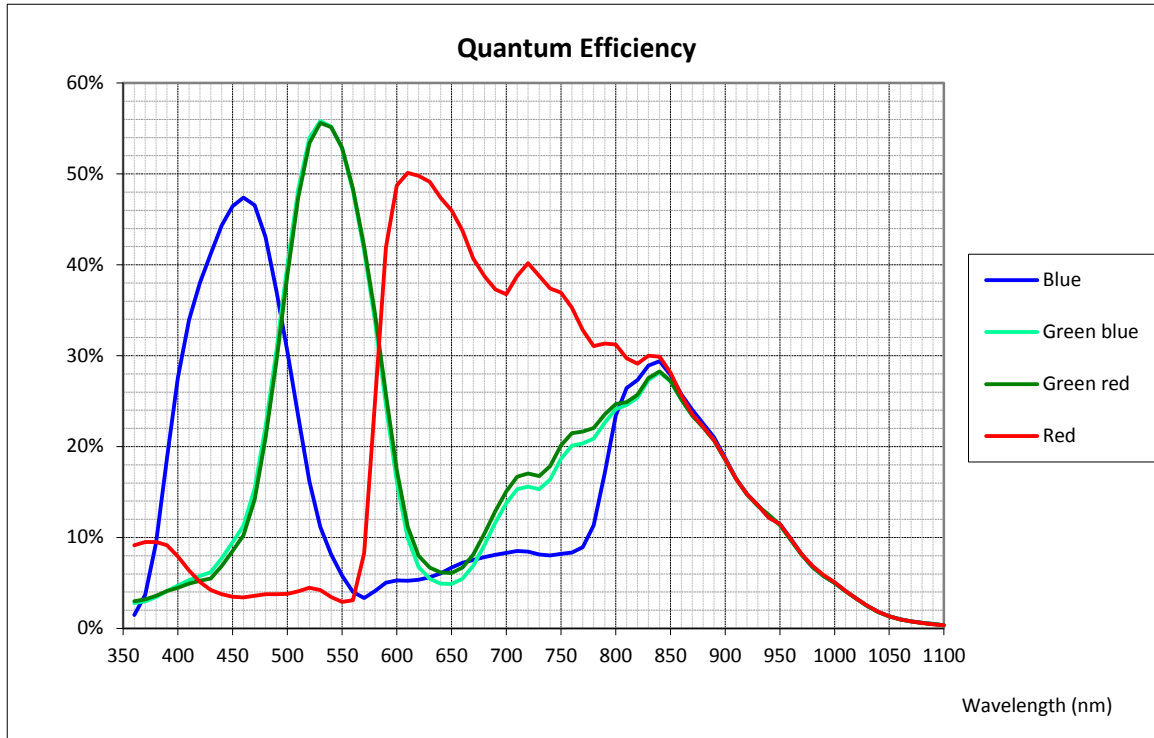

Spectral Response

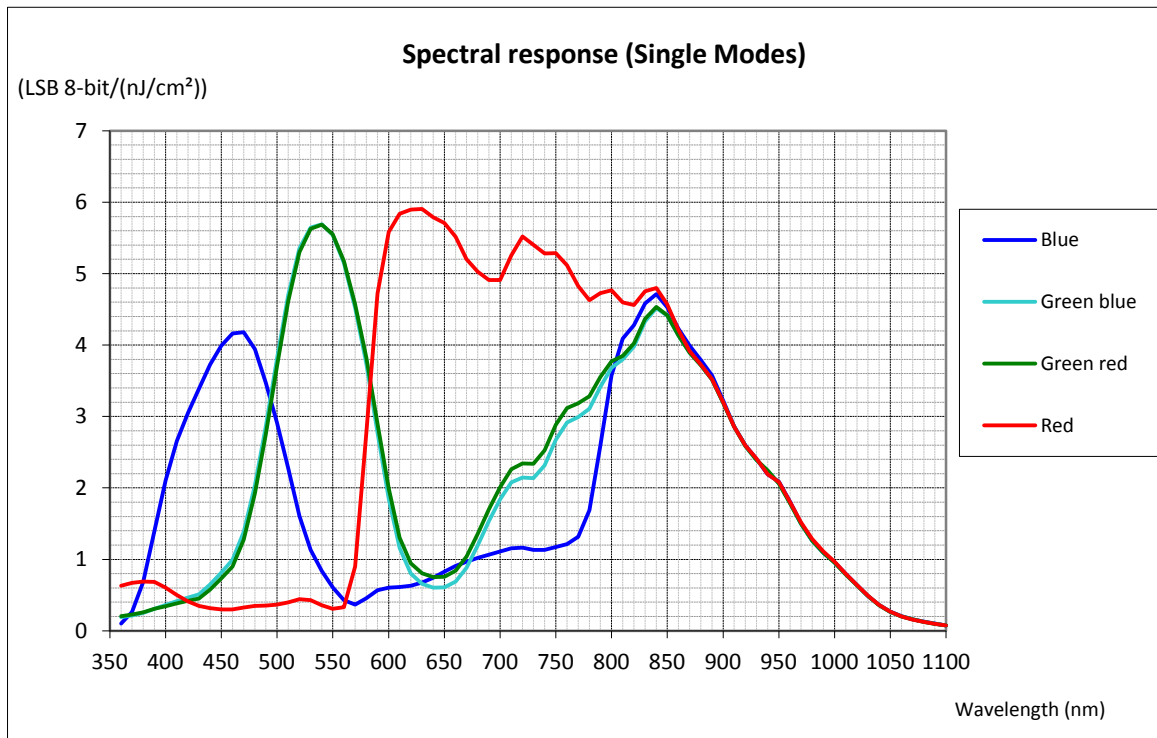

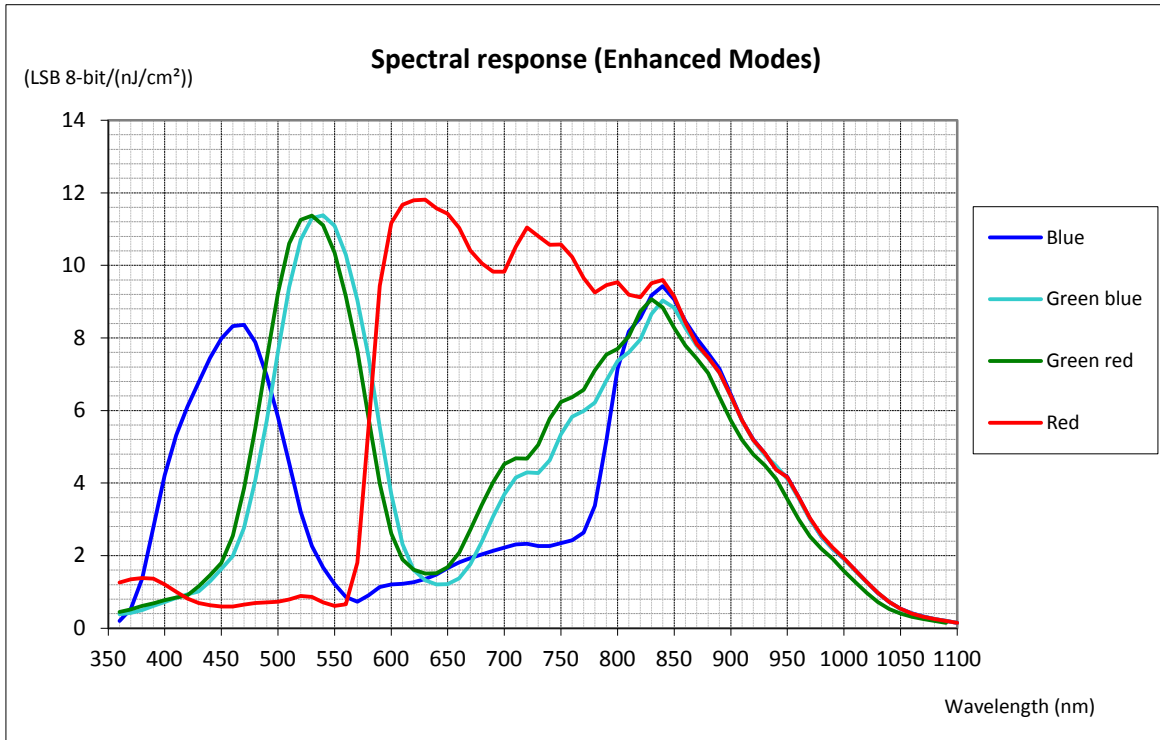

Camera Hardware Interface

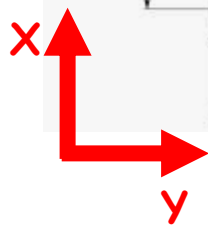
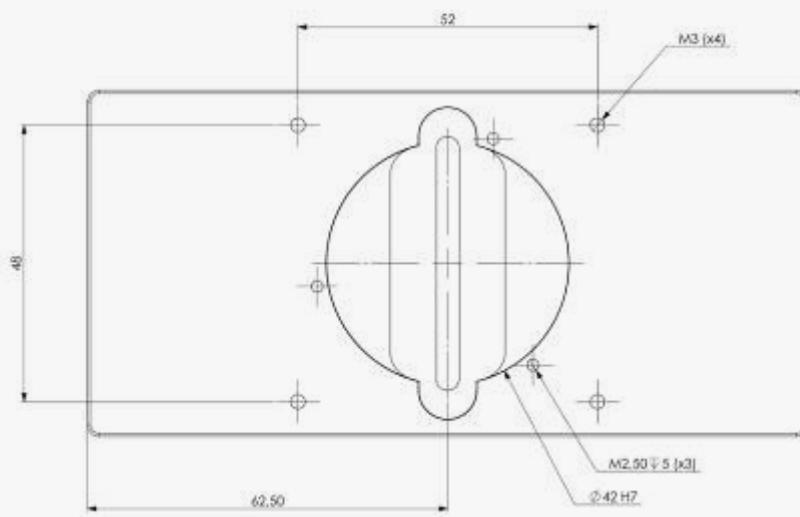
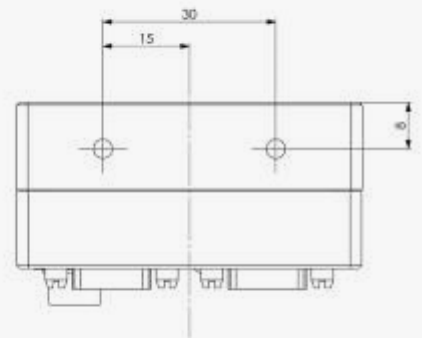
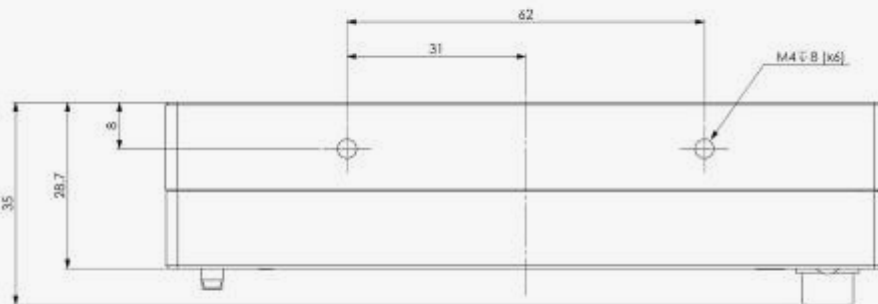
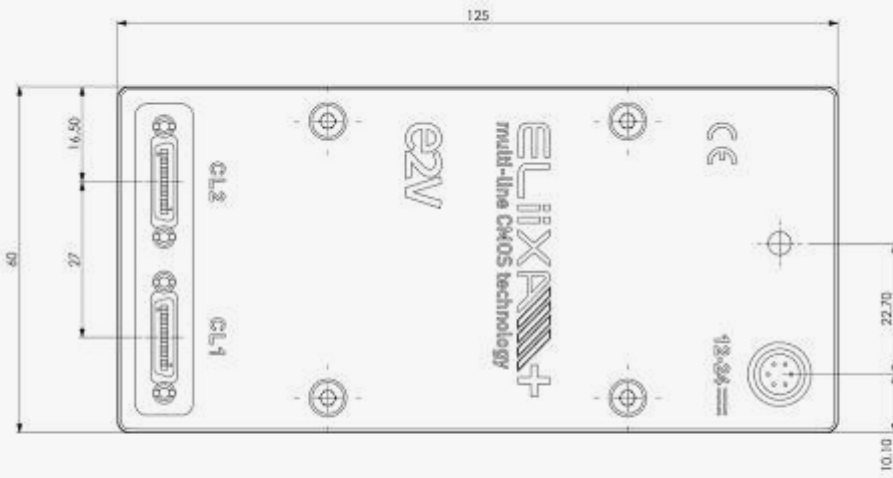

Input/output Connectors and LED

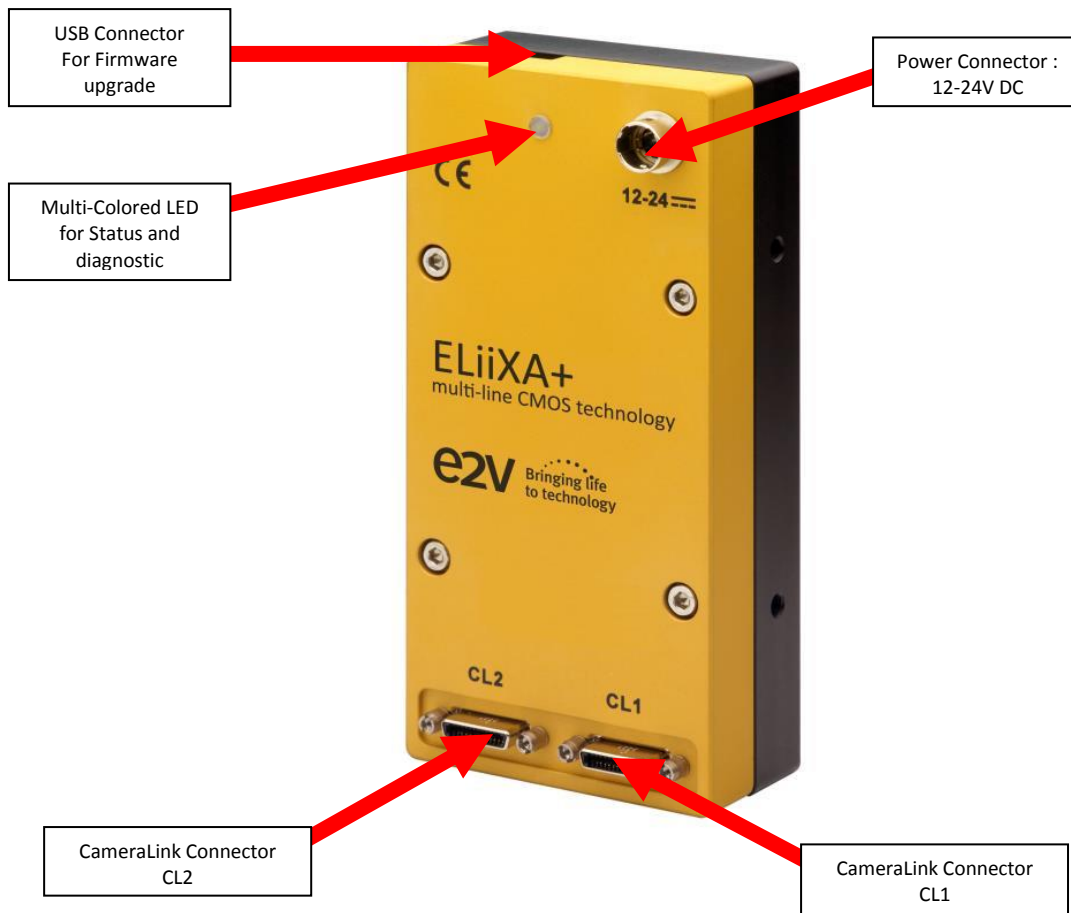

Power Connector

Camera connector type: Hirose HR10A-7R-6PB (male)

Cable connector type: Hirose HR10A-7P-6S (female)

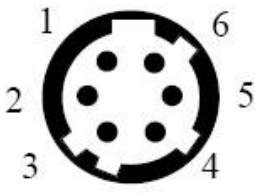
 <p>Camera side description</p>	Signal	Pin	Signal	Pin
	PWR	1	GND	4
	PWR	2	GND	5
	PWR	3	GND	6
Power supply from 12 to 24v Power 7,5W max with an typical inrush current peak of 1A during power up				

CameraLink Output Configuration

	Adjacent Channels
Base : 3 Channels RGB 8bits	3 x 85MHz
Medium : 2 x 3 Channels RGB 8bits	2x 3 x 85MHz
Full : 8 Channels 8bits	8 x 85MHz
Deca : 10 Channels 8bits	10 x 85MHz

Standard Conformity

The ELIIXA+ cameras have been tested using the following equipment:

- A shielded power supply cable
- A Camera Link data transfer cable ref. **MVC-1-1-5-2M** from CEI (Component Express, Inc.)

e2v recommends using the same configuration to ensure the compliance with the following standards.

CE Conformity

The ELIIXA+ cameras comply with the requirements of the EMC (European) directive 2004/108/EC (EN50081-2, EN 61000-6-2).

FCC Conformity

The ELIIXA+ cameras further comply with Part 15 of the FCC rules, which states that: Operation is subject to the following two conditions:

- This device may not cause harmful interference, and
- This device must accept any interference received, including interference that may cause undesired operation

This equipment has been tested and found to comply with the limits for Class A digital device, pursuant to part 15 of the FCC rules. These limits are designed to provide reasonable protection against harmful interference when the equipment is operated in a commercial environment. This equipment generates, uses and can radiate radio frequency energy and, if not installed and used in accordance with the

instruction manual, may cause harmful interference to radio communications. Operation of this equipment in a residential area is likely to cause harmful interference in which case the user will be required to correct the interference at his own expense.

Warning: Changes or modifications to this unit not expressly approved by the party responsible for compliance could void the user's authority to operate this equipment.

RoHs Conformity

ELIIXA+ cameras comply with the requirements of the RoHS directive 2011/65/EU.

Models

Part Number	Definition / Max Speed	True Color / TC Enhanced	Full Definition / FD Enhanced	New Sensor Generation	RGB Matrix
EV71YC4CCL8005-BA0	8k/50kHz – 4k/66kHz	Yes	Yes	With new Release	No
EV71YC4CCL8005-BH0	8k/50kHz	No	Yes	Yes	Yes
EV71YC4CCL4010-BH0	4k/66kHz	Yes	No	Yes	Yes