

# Piranha HS NIR 8k Camera

TDI Line Scan Camera with Enhanced QE in Near-Infrared



## Improved sensitivity in near-infrared wavelengths

For certain applications—such as solar cell inspection—improved sensitivity in the near-infrared region is critical for capturing images beyond the visible spectrum.

Teledyne DALSA's Piranha HS NIR 8k TDI camera is designed to meet the requirements of applications imaging in the near-infrared wavelengths. TDI technology enables multiple exposures to achieve excellent signal-to-noise ratio at high speeds and under low light conditions.

This High Sensitivity NIR camera extends Teledyne DALSA's industry leading high sensitivity product line and provides a cost-effective solution for imaging in the near-infrared wavelengths from 700 nm to 1050 nm.

### Key Features

- Imaging in near-infrared
- 8192 pixels with 256 TDI stages
- 34 kHz line rate, max
- 281 Mpix/s throughput
- Bidirectional operation
- Lateral antiblooming
- Camera Link interface

### Programmability

- Selectable TDI stages—16, 64, 128, 192, 240, 256
- Area mode of operation for ease of alignment
- Up to four user sets of coefficients
- Mirroring and forward / reverse control
- Flat field correction

### Typical Applications

- Solar cell inspection
- PCB / Electronics inspection
- Large web applications
- Food and drug inspection

### Specifications

Resolution	8192 x 256 TDI pixels
Data Rate	281 Mpix/s
Max. Line Rate	34 kHz
Pixel Size	7 $\mu\text{m}$ x 7 $\mu\text{m}$
Data Format	8 bit or 12 bit, selectable
Output	Camera Link
Lens Mount	M72 x 0.75
Responsivity @ 1000 nm	430 DN <sub>8-bit</sub> / (nJ/cm <sup>2</sup> ) @ 0 dB
Broadband Responsivity	1240 DN <sub>8-bit</sub> / (nJ/cm <sup>2</sup> ) @ 0 dB
Dynamic Range	62 dB
Nominal Gain Range	0 dB to + 20 dB
Size	150 mm x 80 mm x 65 mm
Mass	650 g
Operating Temp	0 °C to 50 °C
Power Supply	12 V to 15 V DC
Power Dissipation	18.5 W
Regulatory Compliance	CE and RoHS
Control	MDR26 Camera Link
Data	Shared with Control
Power	Hirose HR10 6-pin
Part Number	HN-80-08K40-00-R

# Piranha HS NIR 8k Camera

TDI Line Scan Camera with Enhanced QE in Near-Infrared

Improved sensitivity in near-infrared wavelengths. NIR imaging up to a wavelength of 1050 nanometers.

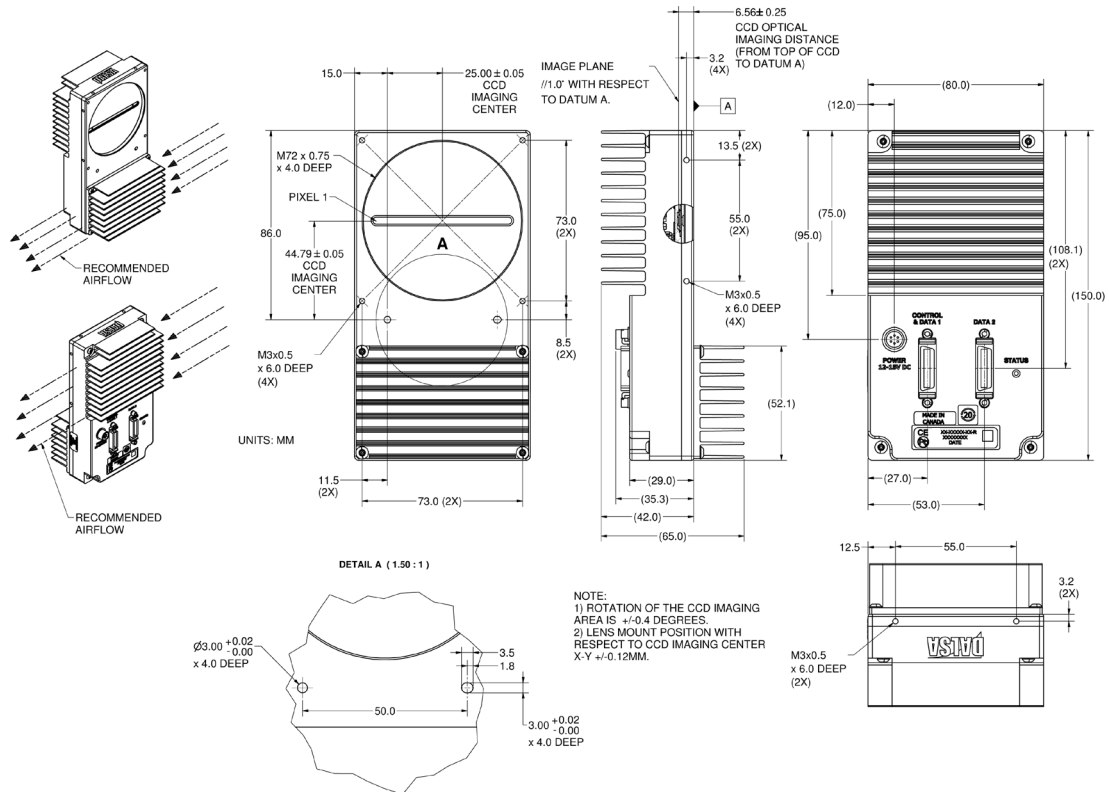
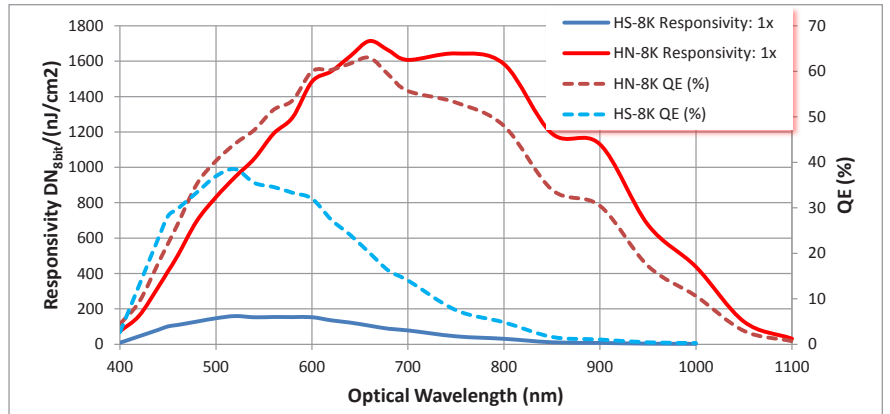

[www.teledynedalsa.com](http://www.teledynedalsa.com)

## Americas

Boston, USA  
+1 978-670-2000  
sales.americas@teledynedalsa.com

## Europe

Krailling, Germany  
+49 89-89-54-57-3-80  
sales.europe@teledynedalsa.com

## Asia Pacific

Tokyo, Japan  
+81 3-5960-6353  
sales.asia@teledynedalsa.com

Shanghai, China  
+86 21-3368-0027  
sales.asia@teledynedalsa.com

Teledyne DALSA has its corporate offices in Waterloo, Canada  
Teledyne DALSA reserves the right to make changes at any time without notice. Teledyne DALSA © 2012.  
Revision number 03-070-20043-02. Revision date October 05 2012.

