

Falcon HG Series

VGA300 / 1M120 / 1.4M100 Area Scan Cameras



Key Features

- High responsivity
- Fast frame rates
- Global shutter and reset
- Exposure control
- Concurrent integration and readout
- Faster frame rates through vertical windowing
- Power over Camera Link
- Mini-Camera Link
- 10 meter transmission @ 80 MHz

Programmability

- Flat field correction
- Adjustable timing modes
- Adjustable gain and offset
- Test patterns and camera diagnostics

Typical Applications

- Electronics manufacturing — AOI and pick and place
- Semiconductor inspection
- Industrial metrology (gauging)
- Print registration
- Flat panel display inspection
- General machine vision

Overview

High responsivity, incredibly fast frame rates, and multiple resolutions.

The Falcon HG series of cameras is comprised of three monochrome cameras of different resolutions: a VGA version running up to 300 fps, a one-megapixel (1024 x 1024) version running at 120 fps, and a highly responsive 1.4 megapixel resolution running at 100 fps. The combination of high frame rates, superior image quality and multiple resolutions make the Falcon HG cameras well suited for applications in electronics inspection, semiconductor inspection, industrial metrology (gauging) and other machine vision applications. By using CMOS technology these cameras consume low amounts of power and are compliant with the power over Camera Link (PoCL) standard. PoCL eliminates the need for a separate power cable and simplifies cable and system integration. Fully programmable, the Falcon HG cameras incorporate exposure control, gain and offset adjustment, and flat-field correction to optimize system performance. Delivered in a robust, compact body, this camera should be your definitive choice for area-based systems.

Specifications

Resolution	VGA300 — 640 (H) x 480 (V) 1M120 — 1024 (H) x 1024 (V) 1.4M100 — 1400 (H) x 1024 (V)
Data Rate	2 x 80 MHz
Max. Line/Frame Rate	VGA300 — 300 fps 1M120 — 120 fps 1.4M100 — 100 fps
Pixel Size	7.4 μm
Data Format	8 or 10 bit — (VGA300 and 1M120: 8 bits only, 1.4M100: up to 10 bits)
Output	Base mini-Camera Link. PoCL compatible
Lens Mount	C-mount
Responsivity	30 DN/(nJ/cm ²) @ 1x gain
Dynamic Range	50 dB
Nominal Gain Range	4x digital
Size	44 x 44 x 44 mm
Mass	< 175 g
Operating Temp	0 °C to 50 °C
Power Supply	12V to 15V DC
Power Dissipation	<3 W
Regulatory Compliance	CE and RoHS
Control and Data	SDR26 mini-Camera Link
Power	Hirose 6 pin circular, or PoCL (shared with control)
Example Part Number	FA-21-3HK3H-00-R



Falcon HG Series

VGA300 / 1M120 / 1.4M100 Area Scan Cameras

With its high responsivity and speed you can inspect more products in a shorter amount of time.

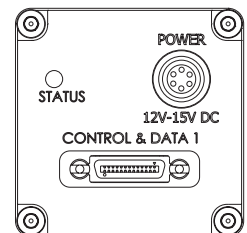
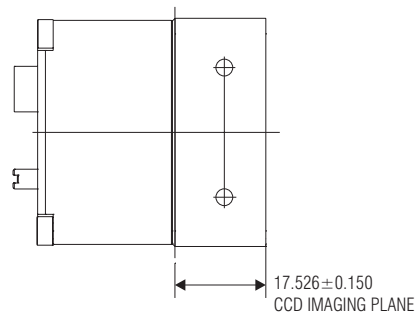
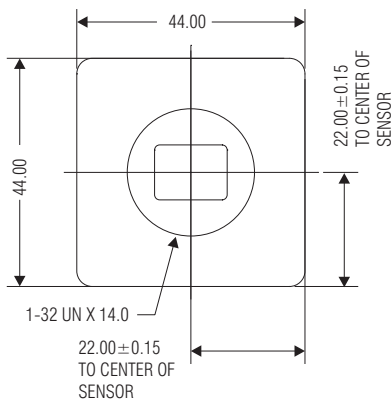
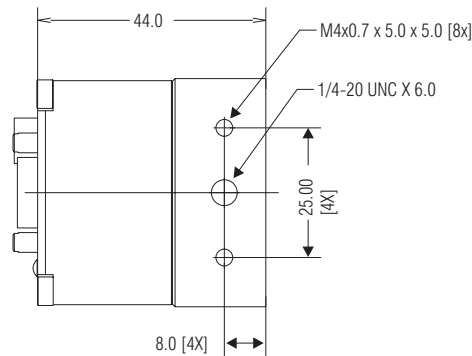
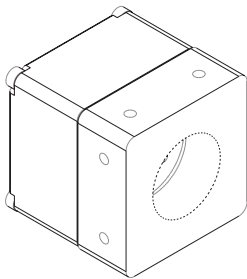
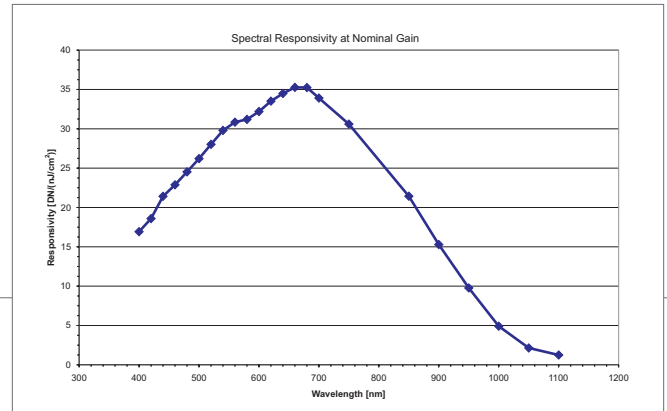

Units: mm.

www.teledynedalsa.com

Americas

Boston, USA
Tel: +1 978-670-2000
sales.americas@teledynedalsa.com

Europe

Munich, Germany
Tel: +49 8142-46770
sales.europe@teledynedalsa.com

Asia Pacific

Tokyo, Japan
+81 3-5960-6353
sales.asia@teledynedalsa.com

Teledyne DALSA is an international leader in digital imaging and semiconductors and has its corporate offices in Waterloo, Ontario, Canada.



All trademarks are registered by their respective companies. Teledyne DALSA reserves the right to make changes at any time without notice. © Teledyne DALSA 2011. 03-070-20034-01