

Piranha HS HS-S0-12Kxx

High Sensitivity Line Scan Cameras

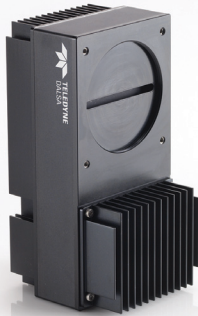

Key Features

- 12,000 pixels
- 5.2 μm pixel size
- Max 90 kHz line rate
- Up to 1.08 Gpix/s
- Responsivity 300 DN/(nJ/cm²) @ 0 dB, 8 bit
- Bidirectional
- Antiblooming
- HSLink interface

Programmability

- Up to 256 TDI stages selectable
- Selectable area mode of operation for ease of alignment
- Up to four sets of flat field correction coefficients
- Mirroring and forward/reverse control
- Flat field corrections

Typical Applications

- Flat panel display inspection
- PCB/electronics inspection
- Large web applications
- High performance document scanning
- Low light applications

Overview

12k resolution, 1.08 gigapixels per second throughput, and a fast 90 kHz line rate

The Piranha HS 12k high sensitivity camera heralds a breakthrough in TDI digital imaging technology. With a maximum line rate of 90 kHz, a throughput of 1.08 gigapixels per second, and 12,000 pixel resolution, the Piranha HS 12k camera provides optimal system performance in a compact form factor.

Using our new HSLink interface technology, this HS 12k camera is the first standard product in the marketplace capable of transmitting over 1 gigapixel per second throughput.

The camera is capable of bidirectional operation with up to 256 stages of selectability, while preventing overexposure with antiblooming features. Camera configuration is flexible and all software is controllable.

Specifications

Resolution	12000 x 256 pixels TDI
Data Rate	Up to 1.08 Gpix/s
Max. Line/Frame Rate	90 kHz
Pixel Size	5.2 μm x 5.2 μm
Data Format	8 bit
Output	HSLink
Lens Mount	M72 x 0.75
Responsivity	300 DN/(nJ/cm ²) at 0 dB, 8 bit
Dynamic Range	500:1
Nominal Gain Range	0 dB to 20 dB
Size	180 mm (H) x 90 mm (W) x 92.1 mm (D)
Mass	< 1500 g
Operating Temp	0 °C to 50 °C
Power Supply	24 VDC
Power Dissipation	< 39 W
Regulatory Compliance	RoHS and CE
Control	HSLink
Data	Shared with Control
Power	Lemo 2 pin
Example Part Number	HS-S0-12k40-00-R

Piranha HS HS-S0-12Kxx

High Sensitivity Line Scan Cameras

A breakthrough High Sensitivity TDI camera.

HS12K Responsivity @ 0 dB

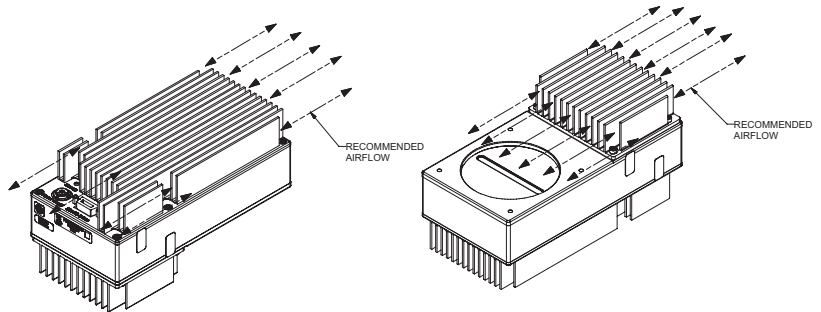
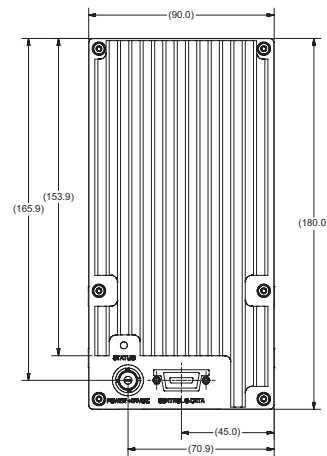
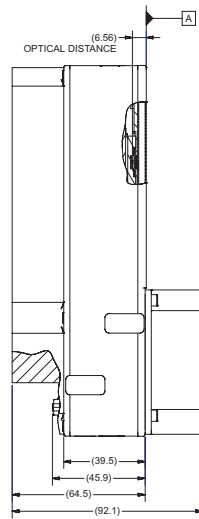
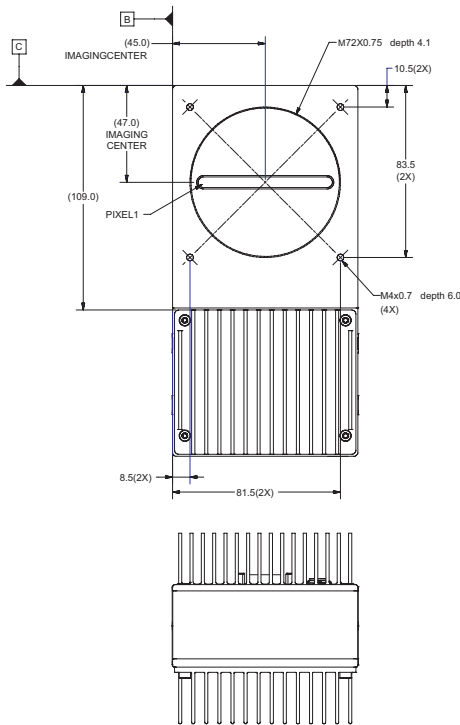
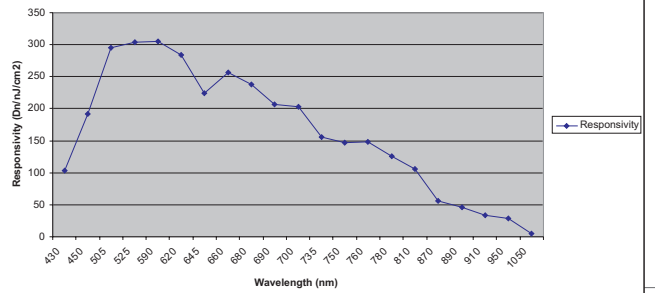

Notes:

- 1) Imaging area aligned in X-Y with respect to datums B and C.
- 2) Rotation of the CCD imaging area is ± 0.6 degrees.
- 3) Lens mount position with respect to imaging area, X-Y ± 0.175 MM.
- 4) Imaging area position tolerances are to be determined.
- 5) Units: MM.

www.teledynedalsa.com

Americas

Boston, USA
Tel: +1 978-670-2000
sales.americas@teledynedalsa.com

Europe

Munich, Germany
Tel: +49 8142-46770
sales.europe@teledynedalsa.com

Asia Pacific

Tokyo, Japan
+81 3-5960-6353
sales.asia@teledynedalsa.com

Teledyne DALSA is an international leader in digital imaging and semiconductors and has its corporate offices in Waterloo, Ontario, Canada.

All trademarks are registered by their respective companies. Teledyne DALSA reserves the right to make changes at any time without notice. © Teledyne DALSA 2011. 03-070-20035-01

