

Genie TS-M2048

Area Scan Monochrome Cameras



Genie TS-M2048

Key Features

- Uses standard PC Ethernet port & hardware
- Supports cable lengths up to 100 m (CAT-5e or CAT-6)
- Simplified set-up with field proven Sopera Essential software featuring CamExpert
- Engineered to accommodate industrial environment with a Ruggedize, screw mount, RJ-45 connector
- Auto-Iris (Video, DC or Motorized)

Programmability

- Higher frame rates achievable in partial scan mode and Multi-ROI support (with up to 16 ROI)
- Global electronic shutter with exposure Control
- Auto-Brightness Feature
- Extended Dynamic Range Function
- On-board flat-field correction
- Multi-Exposure Feature
- Programmable LUTs
- On-board Image compression
- Transfer On-Demand Function
- IEEE1588 Precise time Protocol

Typical Applications

- Electronics manufacturing inspection
- Industrial metrology
- Intelligent traffic systems

Overview

Small compact GigE Vision camera with uncompromised image quality.

The Genie TS-M2048 uses the Cmosis CMOS, CMV4000 Monochrome sensor with a resolution of 2048 x 2048. Teledyne DALSA's "Burst Mode" feature allows for image capture rates of 37.5 fps in 4M pixels resolution while maintaining exceptional image quality. The Genie TS-M2048 takes advantage of gigabit Ethernet technology, transmitting data over standard CAT-5e and CAT-6 cables to distances of up to 100 m. Like all Genie cameras, the TS-M2048 is based on AIA (Automated Imaging Association) GigE Vision Standard to directly link the camera to a PC.



Specifications

Active Resolution	2048 x 2048
Acquisition Frame Rate	37.5 fps
Data Output Transfer	Gigabit Ethernet, also supports 100 Mbps
Pixel Size	5.5 μ m
Data Format	8 and 10-bits
Exposure Control	Automatic, Programmable, or via External Trigger
Dynamic Range	58 dB
Gain Control	Automatic, Manual
I/O Ports	4 opto-isolated input, 4 opto-isolated output, 3 motorized Control, RS-485 Port, and RS-232 Port
Image Buffer	512MB of On-board memory
Lens Mount	CS-MOUNT
Size	49 mm x 49 mm x 54 mm
Mass	~196 g
Operating Temp	-20 to +60c
Power Supply	12 to 24V or Power Over Ethernet (POE)
Power Dissipation	~4.5 to 5.5W
Data Connector	Standard or Screw mount RJ-45
Power and I/O	Micro-D 25-pin and 4-pin auto-Iris
Regulatory Compliance	FCC Class A, CE, RoHs 2004/105/EC
Camera Specification	GigE Vision v1.2 Compliant
Software Platform	Teledyne DALSA Sopera LT or 3rd Party Genicam Compliant SDK
Part Number	G2-GM10-T2041 / G2-GM12-T2041 (Enhance NIR version)

Genie TS-M2048

Area Scan Monochrome Cameras

All Genie cameras feature value added functionality designed specifically for imaging and machine vision applications. All features are easily accessible with Teledyne DALSA's advanced software tools. These tools deliver superior image capture, performance, and control.

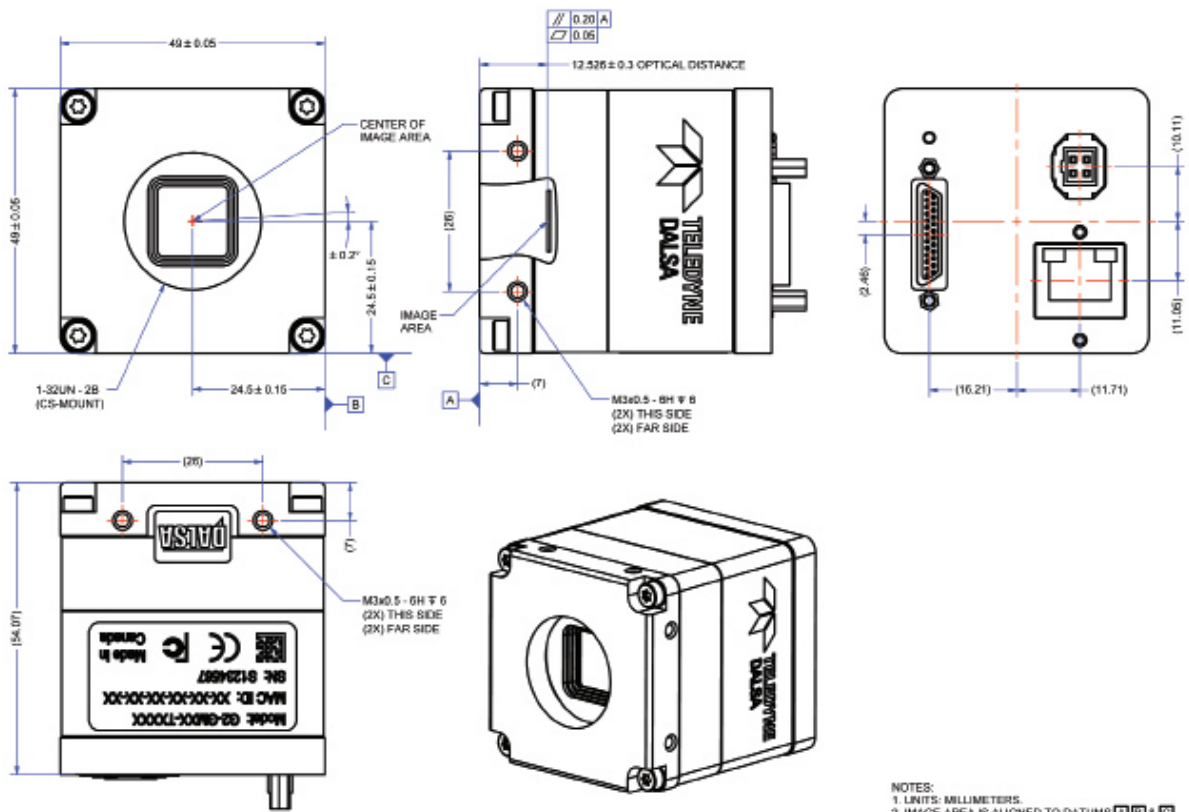
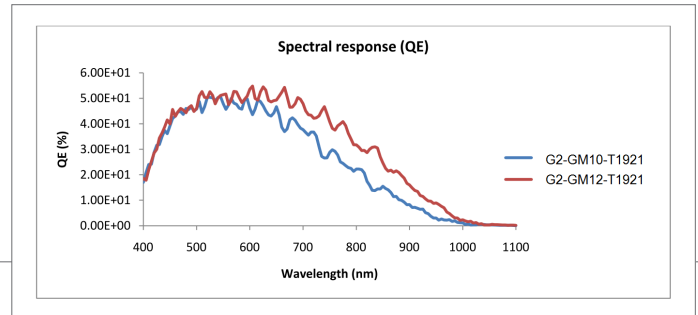

www.teledynedalsa.com

Americas

Boston, USA
 +1 978-670-2000
sales.americas@teledynedalsa.com

Europe

Krailling, Germany
 +49 89-89-54-57-3-80
sales.europe@teledynedalsa.com

Asia Pacific

Tokyo, Japan
 +81 3-5960-6353
sales.asia@teledynedalsa.com

Shanghai, China
 +86 21-3368-0027
sales.asia@teledynedalsa.com

Teledyne DALSA has its corporate offices in Waterloo, Canada
 Teledyne DALSA reserves the right to make changes at any time without notice. Teledyne DALSA © 2013.

