

Piranha4 P4-CM-08K070-00-R

Mono Dual Line Scan CMOS Camera

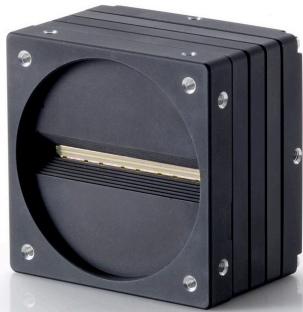

Faster and more responsive. The new Piranha4 8k dual line scan CMOS camera has arrived.

Based on Teledyne Dalsa's unique line scan CMOS sensor architecture, the new Piranha4 8k dual line scan camera provides outstanding signal-to-noise for high speed imaging. The P4-8k has 8k resolution with a $7\ \mu\text{m} \times 7\ \mu\text{m}$ pixel size for optimized optical design. The camera delivers a maximum line rate of 70 kHz in a high responsivity summing mode.

Precise sensor alignment simplifies multiple camera calibration at the system level and an advanced GenICam™ compliant interface makes the camera easier to setup, control, and integrate. Programmability includes exposure control, flat field correction, and gain settings.

The Piranha4 8k camera is ideal for flat panel display, printed circuit board, solar cell, film, and large format web inspection.

Key Features

- Dual line CMOS line scan
- 8k pixel resolution
- Line rates up to 70 kHz
- 100% fill factor
- Exposure control
- 100x antiblooming
- Camera Link interface
- GenICam or ASCII command compliant interfaces

Programmability

- Save up to eight sets of flat-field correction coefficients
- Adjustable gain and offset
- Lens and shading correction
- Test pattern and diagnostics

Typical Applications

- Flat-panel display inspection
- Printed circuit board inspection
- Parcel sorting
- High performance document scanning
- High throughput applications

Specifications

Resolution	8192 x 2 pixels
Line Rate	70 kHz Max
Pixel Size	7.04 μm x 7.04 μm
Data Format	8 bit or 12 bit selectable
Output	Camera Link
Lens Mount	M72 x 0.75
Responsivity	276 DN / (nJ / cm ²) broadband @ 1x gain, 12 bit
Dynamic Range	63 dB
Nominal Gain Range	1x to 10x
Size	80 mm (W) x 80 mm (H) x 57 mm (D)
Mass	700 g
Operating Temp	0 °C to 50 °C, measured at the front plate
Power	Hirose 6-pin male, +12 VDC to +24 VDC
Power Dissipation	16 W
Control & Data	Camera Link
Regulatory Compliance	CE and RoHS
Part Number	P4-CM-08K070-00-R

Piranha4 P4-CM-08K070-00-R

Mono Dual Line Scan CMOS Camera

With line rates up to 70 kHz and 8k resolution, this camera inspects and detects with unrivalled precision, speed, and responsivity.

The new Piranha4 camera takes machine vision to the next level.

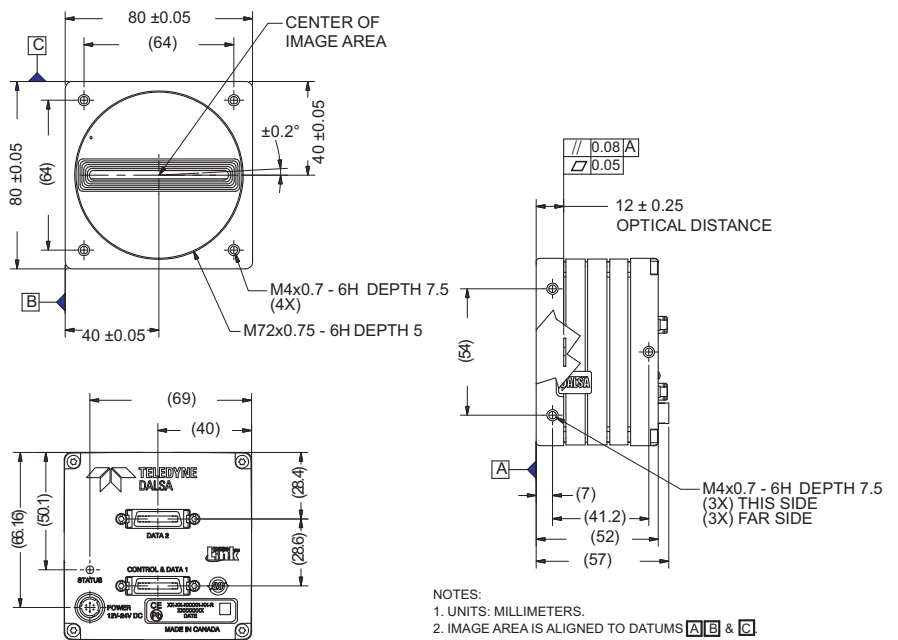
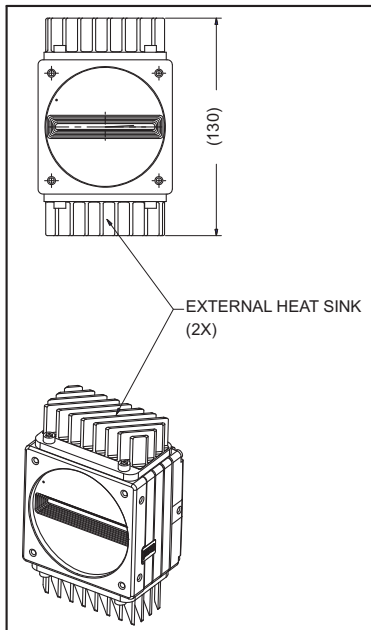
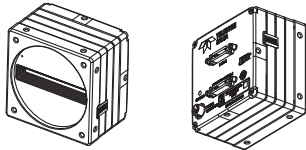
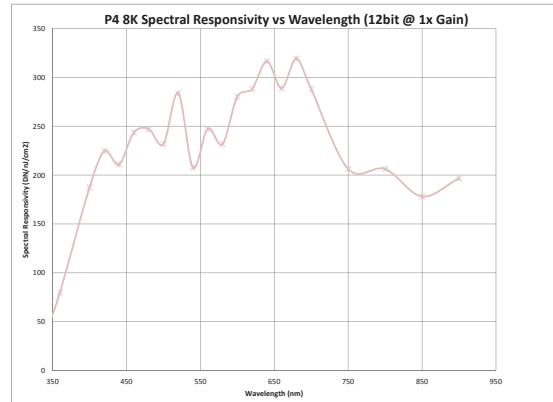

www.teledynedalsa.com

Americas

Boston, USA
 +1 978-670-2000
sales.americas@teledynedalsa.com

Europe

Krailling, Germany
 +49 89-89-54-57-3-80
sales.europe@teledynedalsa.com

Asia Pacific

Tokyo, Japan
 +81 3-5960-6353
sales.asia@teledynedalsa.com

Shanghai, China
 +86 21-3368-0027
sales.asia@teledynedalsa.com